

Salivary Bypass Tubes

Hood Salivary Bypass Tubes are designed to control salivary leakage from the pharyngocutaneous fistula after total laryngectomy, and to stent the cervical esophagus following dilation of a stricture. Bypass tubes are frequently used in patients with poor wound healing due to systemic problems (e.g., poor nutritional status, metabolic disorders) or regional factors (e.g., postirradiation changes, recurrent or persistent neoplasm, chronic infection). Because of these host factors, placement of the tubes may be associated with pressure necrosis of local tissues. Therefore, patients with these tubes in place should be monitored carefully by x-ray and direct inspection if localized pressure necrosis of regional soft tissue is suspected. The tubes are designed to fit securely in the superior esophagus and hypopharynx. However, it is possible for a loose-fitting tube to be displaced distally into the esophagus. This may be prevented by securing the tube to an indwelling gastric tube.

The Hood Intended Use and Instruction Manual, which is supplied with each product, provides detailed information on insertion and removal technique, sterilization and postoperative care.

- **Cost-effective alternative to laser therapy with equal palliation of esophageal carcinoma**
- **Funnel shaped superior end conforms to hypopharynx**
- **Flexible with a large I.D./O.D. ratio allowing maximum nutritional intake**
- **Enables spontaneous closure of a fistula**
- **Soft implant grade silicone**

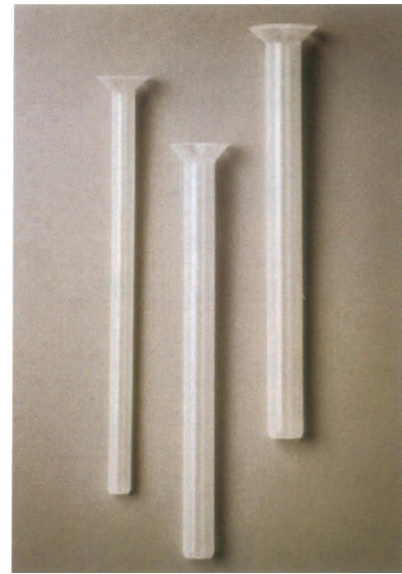
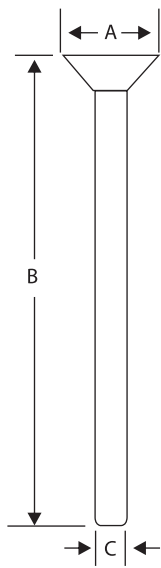

Ordering information

Salivary Bypass Tubes

Code No.	Diameter C	Size (mm) A	Size (mm) B
SBT-08	8mm (0.0.) for use with No. 10 nasogastricfeeding tube	20	188
SBT-10	10mm (0.0.) for use with No. 12 nasogastricfeeding tube	24	188
SBT-12	12mm (0.0.) for use with No. 14-16 nasogastricfeeding tube	24	188
SBT-14	14mm (0.0.) for use with No. 16 nasogastricfeeding tube	27	188
SBT-16	16mm (0.0.) for use with No. 16 nasogastricfeeding tube	30	185
SBT-18	18mm (0.0.) for use with No. 16 nasogastricfeeding tube	32	188
SBT-20	20mm (0.0.) for use with No. 16 nasogastricfeeding tube	34	185

Silicon Block

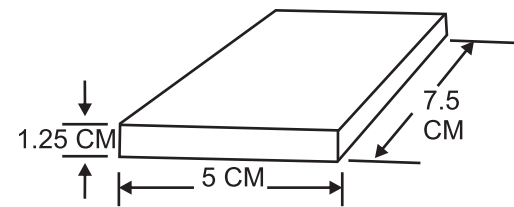

Description:

Implantable silicone block for use in augmentation of bone or cartilaginous features as well as designing the prosthesis in ENT / Head-Neck Surgery.

Special advantages:

May be carved with a knife or scissor. Will not attach to underlying or surrounding tissues. Can be repeatedly autoclaved.

Indications:

For use in designing Mandibular as well as nasal prosthesis and also for Thyroplasty.

SolaTone Plus

Electronic Speech Aid

SolaTone Plus Code - 7438 - Qty. 1 pc

- Affordable and simple to use with external tone and volume adjustments
- Quality sound, voice range and construction
- Includes rechargeable AA batteries for your convenience and longer use time
- USB charging-plug it in like a mobile phone
- Plug it in at night, have full charge by morning
- Compact and light weight



TruTone EMOTE

TruTone EMOTE Code - 7439 - Qty. 1 pc

Allows for variance in the tone of voice to let emotions be heard

- The exclusive Emotion™ Button is easy to use

Allows change in voice volume from whispering to loud

- Check out the exclusive Whisper mode for monotone users

Simple and easy to use

- Intuitive adjustments, no tools needed
- Easy-set modes for push-button simplicity
- Quick and easy monotone modes

Proven intelligibility

- Published study proves intelligibility

Comfortable, ergonomic and sleek design

- Hourglass design for better grip

Up to a month battery life and USB charging

- Charges just like your phone
- Most users experience 25-35 days between charges



Urmee Healthcare

G-1, Asho Plalav, (Jwala Estate),
Opp. Flyover Bridge, S.V. Road,
Borivali (W), Mumbai - 400 092. INDIA
+91 22 2899 2361, 6694 9516
Telefax : +91 22 28053816
Email : deena@vsnl.com



LARYNGOLOGY

Hood Tracheal T-Tube Ultra-smooth Plus

Standard Tracheal T-Tubes

Hood Tracheal T-Tubes are designed with the stopper plug attached to the extraluminal limb to ensure the most secure placement, and to offer convenience in daily cleaning, maintenance and training. The single-piece construction eliminates misplacement of plugs while medical personnel are developing routine breathing and maintenance. The Ring Flanged Plug can be detached and threaded over the extraluminal limb to fit snugly against the patient's tracheostoma, adding security by reducing excessive movement of the T-Tube. The smooth extraluminal stem provides comfort for a wide range of patients, thin and obese, and eliminates complications in cases of edema.

* **Safety** : placement of T-Tube secured with Ring Flange ensures a no slip fit

* **Comfort** : Ring Flange easily adjusts to neck size

* **Widest range of T-Tube sizes available**

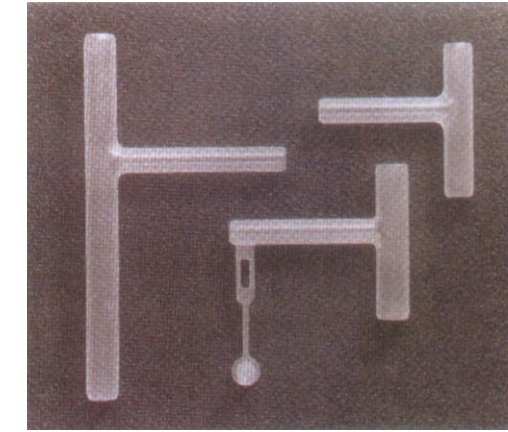

Ordering information

Pediatric and Standard Tracheal T-Tubes

Code No.	ST-506-S	ST-507-S	ST-508-S	ST-509-S	ST-510-S	ST-511-S	ST-512-S	ST-513-S	ST-514-S	ST-515-S	ST-516-S
O.D Size (mm)	6	7	8	9	10	11	12	13	14	15	16
A=	10	13	16	19	23	27	31	31	32	34	31
B=	6	9	12	15	17	20	21	22	23	24	23
C=	48	48	36	40	44	50	55	60	64	64	63
D=	5	6	6	8	8	9	11	11	11	11	12

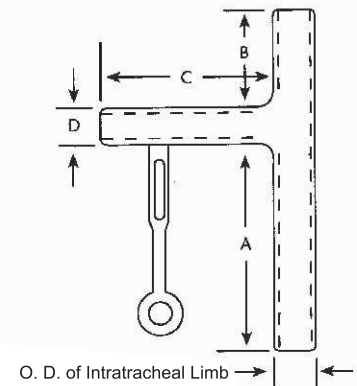

Hood Thoracic T-Tube Ultra-smooth Plus

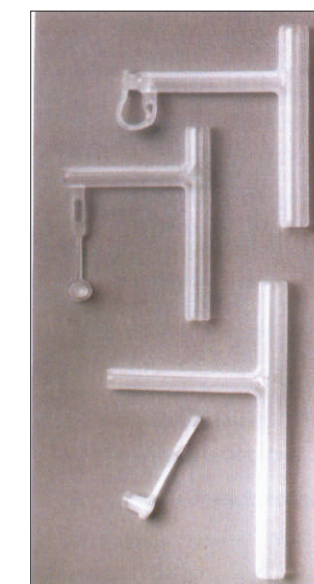

Hood Tracheal and Thoracic T-Tubes enable short-term surgical management of tracheal and subglottic stenosis and the reconstruction of cervical and thoracic trachea. These patented devices are designed to maintain patency of the tracheal airway and to provide respiration through the larynx.

The T-Tubes, made of medical-grade silicone material, will not harden and are nonreactive and nonirritating to ensure patient comfort.

Tracheal T-Tubes with standard and long limbs serve as both a tracheotomy tube and a tracheal stent. Thoracic T-Tubes are designed with extra-long limbs to bypass and stent a tracheal stenosis between the thoracic inlet and the carina.

The Hood Intended Use and Instruction Manual, which is supplied with each product, provides detailed information on insertion and removal technique, sterilization, and postoperative care.

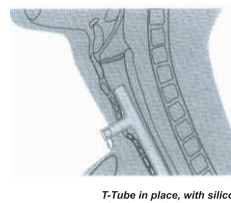
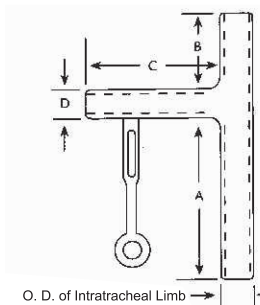

Ordering information

Long Tracheal T-Tubes

Code No.	LT-506-S	LT-507-S	LT-508-S	LT-509-S	LT-510-S	LT-511-S	LT-512-S	LT-513-S	LT-514-S	LT-516-S	LT-518-S
	6	7	8	9	10	11	12	13	14	16	18
A=	34	40	58	63	63	62	72	72	72	81	81
B=	7	8	12	14	17	17	20	20	23	24	24
C=	48	48	39	43	50	55	59	68	66	70	55
D=	5	6	65	8	8	9	11	11	11	12	14

O.D. size corresponds to outside diameter of intratracheal limb in millimeters. patents Applied.

shaded area indicate pediatric sizes.

Extra Long Thoracic T-Tubes (extra-long tubes with free standing plug)

Code No.	EEL-06-S	EEL-07-S	EEL-08-S	EEL-10-S	EEL-12-S	EEL-14-S
Q.D. Size (mm)	6	7	8	10	12	14
A=	40	40	60	68	98	97
B=	30	30	49	48	39	48
C=	48	48	40	41	64	74
D=	5	6	6.5	8	11	11

These tubes are designed to be cut to desired lengths but care must be taken to trim and smooth the cut edges. Custom-cut lengths are available upon request.

Tracheal Stent With Posts Ultra-smooth Plus

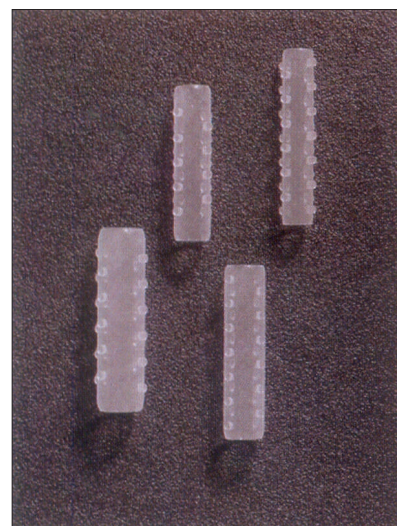

Injury of the upper airway commonly results in stenotic lesions of the larynx, subglottis, and adjacent trachea. The Hood Tracheal Stent with Posts offers physicians an excellent alternative to the traditional approach of surgical correction and YAG laser resection. The device is placed in the trachea at the point of stenosis as a palliative technique for tumors causing extrinsic compression of the large airway. It may also be used for patients with benign tracheostenosis.

The Hood Intended Use and Instruction Manual, which is supplied with each product, provides detailed information on insertion and removal technique, sterilization, and postoperative care.

- Aids in short-term management of airway obstructions after lung transplants, tuberculosis, malignancies
- Aids in normal breathing and speech
- Permits healing and prevents desiccation
- Biocompatible medical-grade silicone
- Posts aid in preventing migration

Ordering information

Available with Ultra-smooth[®] surface treatment. The proprietary technology modifies the surface properties of silicone. Ultra-smooth[®] treated silicone is thromboresistant, resistant to biofilm germination and bacterial and fungal growth, and has less surface friction.

Tracheal Stent with Posts

Code No.	A O.D. (mm)	B Length (mm)
TSP - 1260 - S	12	60
TSP - 1270 - S	12	70
TSP - 1370 - S	13	70
TSP - 1460 - S	14	60
TSP - 1470 - S	14	70
TSP - 1560 - S	15	60
TSP - 1640 - S	16	40
TSP - 1650 - S	16	50
TSP - 1660 - S	16	60
TSP - 1670 - S	16	70
TSP - 1680 - S	16	80
TSP - 1850 - S	18	50
TSP - 1860 - S	18	60
TSP - 1870 - S	18	70
TSP - 1880 - S	18	80
TSP - 1890 - S	18	90

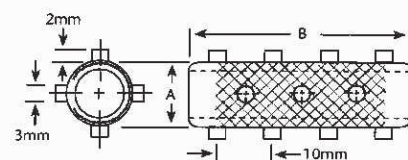

Harrell Y Stent With Posts Ultra-smooth Plus

The Harrell Y Stent[®], designed with James H. Harrell II, M.D., allows physicians to address airway complications such as anastomosis and stenosis. The stent may also be used to minimize chronic bronchial strictures due to tuberculosis and malignancies. The posts help prevent migration of the stent after placement. Inserted endoscopically, the specially designed bifurcated tracheobronchial tube fits snugly into the distal trachea, the carina and the proximal bronchi. Fabricated of flexible, biocompatible, implant-grade silicone, the Harrell Y Stent allows humidification and phonation.

The Hood Intended Use and Instruction Manual, which is supplied with each product, provides detailed information on insertion and removal technique, sterilization, and postoperative care.

* Designed with assistance from James H. Harrell II, M.D.
University of California at San Diego

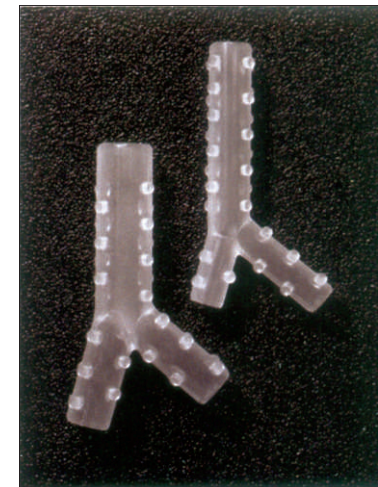

- Aids in short-term management of airway obstructions after lung transplants, tuberculosis, malignancies
- Aids in normal breathing and speech
- Permits healing and helps prevent desiccation
- Biocompatible implant-grade silicone
- Y-Angle anatomically designed
- Posts aid in preventing migration

O.D.1 size corresponds to outside diameter of intratracheal limb in millimeters.

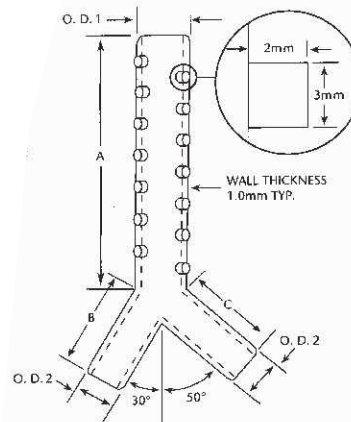

Ordering information

Harrell Y Stent with Posts

Code No.	O.D. 1	O.D. 2	A	B	C
HVP-12-S	12	9.5	50	20	30
HVPS-14-S	14	9.5	50	20	35
HVP-14-S	14	12	50	25	35
HVPS-16-S	16	12	45	25	30
HVP-16-S	16	10	50	30	40

These products have been treated with Ultra-smooth Plus[®] surface treatment. This proprietary technology modifies the surface properties of silicone. Ultra-smooth Plus[®] treated silicone is thromboresistant, resistant to biofilm germination and bacterial and fungal growth, and has less surface friction. See Ultra-smooth Plus[®].

Bronchial Stent With Posts Ultra-smooth Plus

The Hood Bronchial Stent is designed to relieve airway complications such as anastomosis and stenosis following lung transplant. The stent may also be used to minimize chronic bronchial strictures due to tuberculosis and malignancies. Inserted endoscopically, both ends of the tube are flanged to prevent movement after surgical placement in the bronchus. Fabricated of flexible, biocompatible, implant-grade silicone, the bronchial stent allows normal humidification and phonation. Bronchial Stent with Posts (anchoring studs) are also available for physicians who prefer the anchoring stud over the rings on the original design.

The Hood Intended Use and Instruction Manual, which is supplied with each product, provides detailed information on insertion and removal technique, sterilization, and postoperative care.

- Aids in short-term management of airway obstructions after lung transplants, tuberculosis, malignancies.
- Enables normal breathing and speech
- Permits healing and prevents desiccation
- Biocompatible implant-grade silicone
- Additional lengths and diameters are available upon request

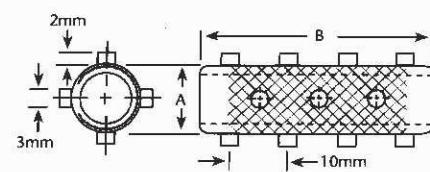

Ordering information

Bronchial Stent with Posts (anchoring studs)

Code No.	A O.D. (mm)	B Length (mm)
BSP-1020-S	10	20
BSP-1030-S	10	30
BSP-1040-S	10	40
BSP-1220-S	12	20
BSP-1230-S	12	30
BSP-1240-S	12	40
BSP-1250-S	12	50
BSP-1430-S	14	30
BSP-1440-S	14	40
BSP-1450-S	14	50



Stents are available with Ultra-smooth Plus[®] surface treatment. This proprietary technology modifies the surface properties of silicone. Advantages include:

- + **Biocompatibility**
Thromboresistant, resistant to biofilm formation, resistant to bacterial and fungal growth
- + **Slippery surface**
Smooth, reduction of friction, no need for lubricants
- + **Extended product life**
Improves hydrophilicity, wear resistant, abrasion resistant, improves fatigue strength
- + **Reduces rates of infection and thrombosis**

Laryngeal Stent

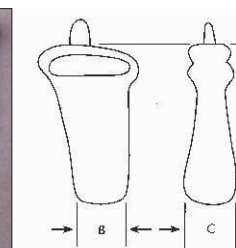

Hood Laryngeal Stents provide soft, solid, conforming support for use in laryngeal fracture, laryngeal stenosis and subglottic stenosis.

Laryngeal stents are molded to a precise hardness to provide support, but not injure surrounding tissue. They bend easily, are compressible and conform to the inner contour of the larynx. Skin or mucosal grafts may be sutured directly to the stent which is then inserted and held in place by silicone surface buttons.

The Hood Intended Use and Instruction Manual, which is supplied with each product, provides detailed information on insertion and removal technique, sterilization, and postoperative care.

- Prevent and treat laryngeal stenosis
- Silicone material prevents tissue reaction
- Designed to conform to normal endolaryngeal surface
- Four sizes are available for precise patient fitting
- Surface buttons provided with suture holes

Ordering information

Laryngeal Stents

Size	Code	Millimeters		
		A	B	C
Child	LSC - 10	33	10	9
Adolescent	LSA - 15	37	10	11
Female (Adult)	LSF - 25	40	12	10
Male (Adult)	LSM - 30	47	15	16
Additional Buttons	LSB - 50			

Laryngeal Umbrella Keel

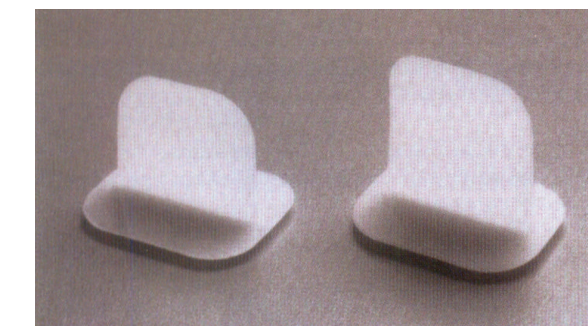

Hood Laryngeal White Umbrella Keels are designed for use following repair of anterior laryngeal stenosis, subsequent to removal of a laryngeal stent, to insure reformation of a sharp anterior commissure and to prevent formation of an anterior web. Clear umbrella keels are also available. Both are indicated for use after hemilaryngectomy to prevent stenosis.

The soft, solid conforming structure consists of an umbrella-like extra laryngeal cover and a thin intra laryngeal insert. The extra laryngeal surface is secured to the thyroid laminae to protect the thyrotomy repair. It is designed so that, with a figure-of-eight suture, the keel can be held tightly enough to inhibit synchronous motion between the intralaryngeal keel insert and the vocal cords, thus preventing granulation formation and preserving phonation.

The Hood Intended Use and Instruction Manual, which is supplied with each product, provides detailed information on insertion and removal technique, sterilization, and postoperative care.

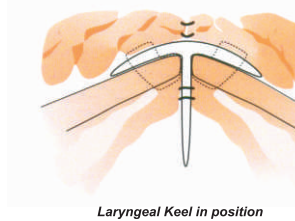

Laryngeal Keel in position

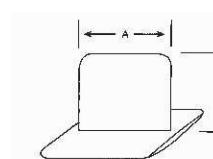

- Precisely molded medical-grade silicone provides for a flexible, thin and non-irritating keel
- Readily conforms to anatomy of the anterior commissure
- White umbrella keel enables easy visualization for removal
Three sizes are available

Ordering information

Laryngeal Umbrella Keels

Code No.	Type	Size A (mm)	Size B (mm)
LK-12	Clear	17	12
LK-14	Clear	18	14
LK-16	Clear	18	16
RLK-12	White	17	12
RLK-14	White	18	14
RLK-16	White	18	16